

JXD161A SERIES

CHARACTERISTICS :

DISPLAY CONTENT : 16CHAR x 1ROW

CHAR. DOTS : 5 x 8

DRIVING MODE : 1/16D

AVAILABLE TYPES :

TN , STN(YELLOW GREEN、 GREY、 B/W)

REFLECTIVE、 WITH EL OR LED BACKLIGHT

EL/100VAC , 400HZ

LED/4.2VDC

PARAMETER ($V_{DD}=5.0V \pm 10\%$, $V_{SS}=0V$, $T_a=25$)

Parameter	Symbol	Testing Criteria	Standard Values			Unit
			Min.	Typ.	Max	
Supply voltage	$V_{DD}-V_{SS}$	-	4.5	5.0	5.5	V
Input high voltage	V_{IH}	-	2.2	-	V_{DD}	V
Input low voltage	V_{IL}	-	-0.3	-	0.6	V
Output high voltage	V_{OH}	$-I_{OH}=0.2mA$	2.4	-	-	V
Output low voltage	V_{OL}	$I_{OL}=1.2mA$	-	-	0.4	V
Operating voltage	I_{DD}	$V_{DD}=5.0V$	-	1.3	3.0	mA

APPLICATION CIRCUIT

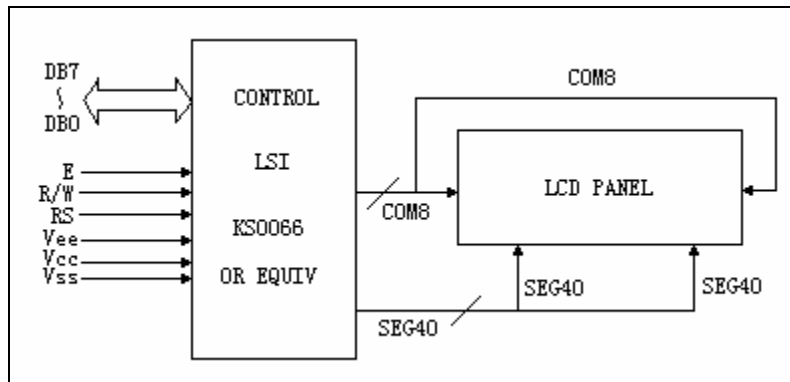

DIMENSIONS/DISPLAY CONTENT

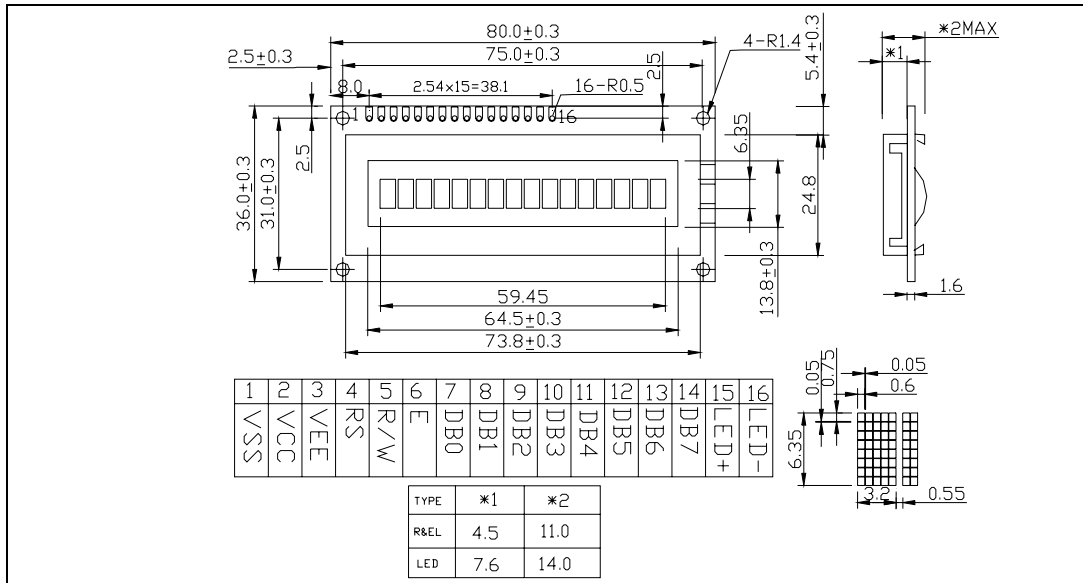

PIN CONFIGURATION

1	2	3	4	5	6	7	8	9	10	11	12	13	14	15	16
VSS	VCC	VEE	RS	R/W	E	DB0	DB1	DB2	DB3	DB4	DB5	DB6	DB7	LED+	LED-

AC Characteristics Read Mode Timing Diagram

Table 12. AC Characteristics ($V_{DD} = 4.5V \sim 5.5V$, $T_a = -30 \sim +85^{\circ}C$)

Mode	Characteristic	Symbol	Min.	Typ.	Max.	Unit
Write Mode (Refer to Fig-6)	E Cycle Time	t_c	500	-	-	ns
	E Rise / Fall Time	$t_{R,tF}$	-	-	20	
	E Pulse Width (High, Low)	t_w	230	-	-	
	R/W and RS Setup Time	t_{su1}	40	-	-	
	R/W and RS Hold Time	t_{H1}	10	-	-	
	Data Setup Time	t_{su2}	80	-	-	
	Data Hold Time	t_{H2}	10	-	-	
Read Mode (Refer to Fig-7)	E Cycle Time	t_c	500	-	-	ns
	E Rise / Fall Time	$t_{R,tF}$	-	-	20	
	E Pulse Width (High, Low)	t_w	230	-	-	
	R/W and RS Setup Time	t_{su}	40	-	-	
	R/W and RS Hold Time	t_H	10	-	-	
	Data Output Delay Time	t_D	-	-	120	
	Data Hold Time	t_{DH}	5	-	-	

Table 13. AC Characteristics ($V_{DD} = 2.7V \sim 4.5V$, $T_a = -30 \sim +85^{\circ}C$)

Mode	Characteristic	Symbol	Min.	Typ.	Max.	Unit
Write Mode (Refer to Fig-6)	E Cycle Time	t_c	1000	-	-	ns
	E Rise / Fall Time	$t_{R,tF}$	-	-	25	
	E Pulse Width (High, Low)	t_w	450	-	-	
	R/W and RS Setup Time	t_{su1}	60	-	-	
	R/W and RS Hold Time	t_{H1}	20	-	-	
	Data Setup Time	t_{su2}	195	-	-	
	Data Hold Time	t_{H2}	10	-	-	
Read Mode (Refer to Fig-7)	E Cycle Time	t_c	1000	-	-	ns
	E Rise / Fall Time	$t_{R,tF}$	-	-	25	
	E Pulse Width (High, Low)	t_w	450	-	-	
	R/W and RS Setup Time	t_{su}	60	-	-	
	R/W and RS Hold Time	t_H	20	-	-	
	Data Output Delay Time	t_D	-	-	360	
	Data Hold Time	t_{DH}	5	-	-	

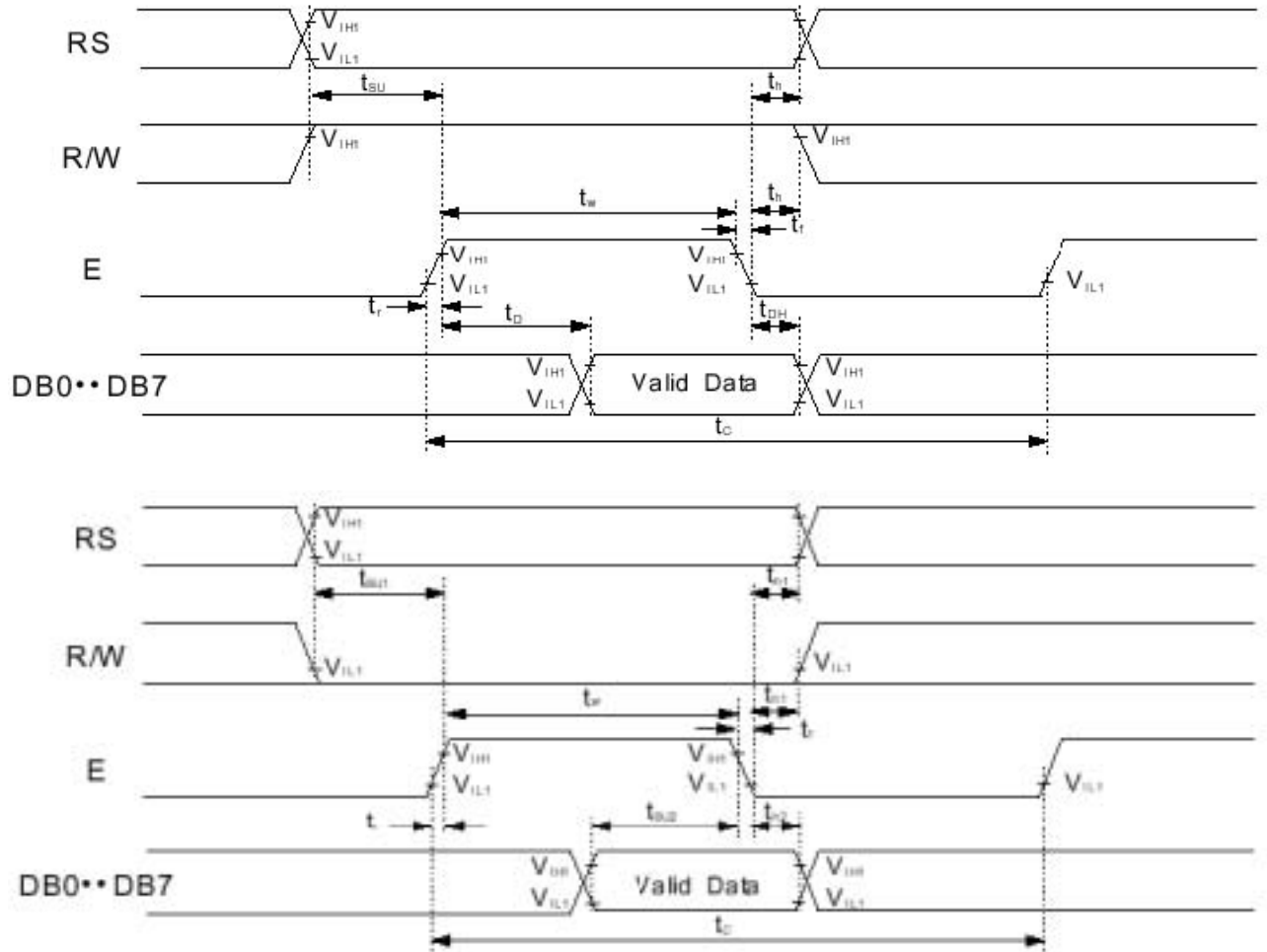

Write Mode Timing Diagram

Timing

1) Interface with 8-bit MPU

When interfacing data length are 8-bit, transfer is performed at a time through 8 ports, from DB0 to DB7. Example of timing sequence is shown below.

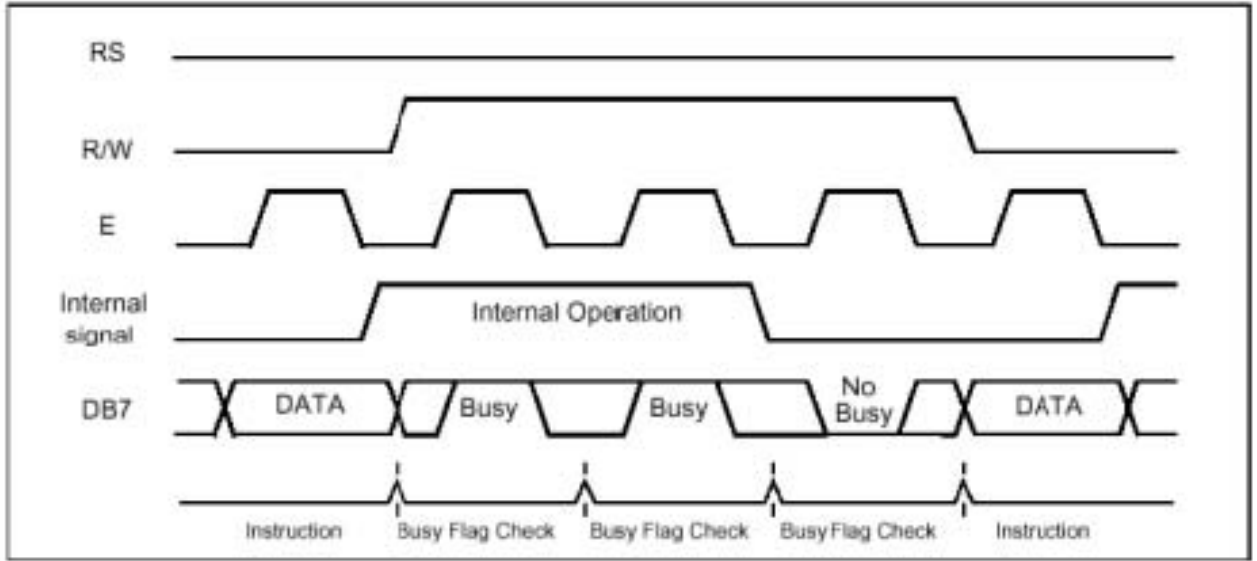

Connection

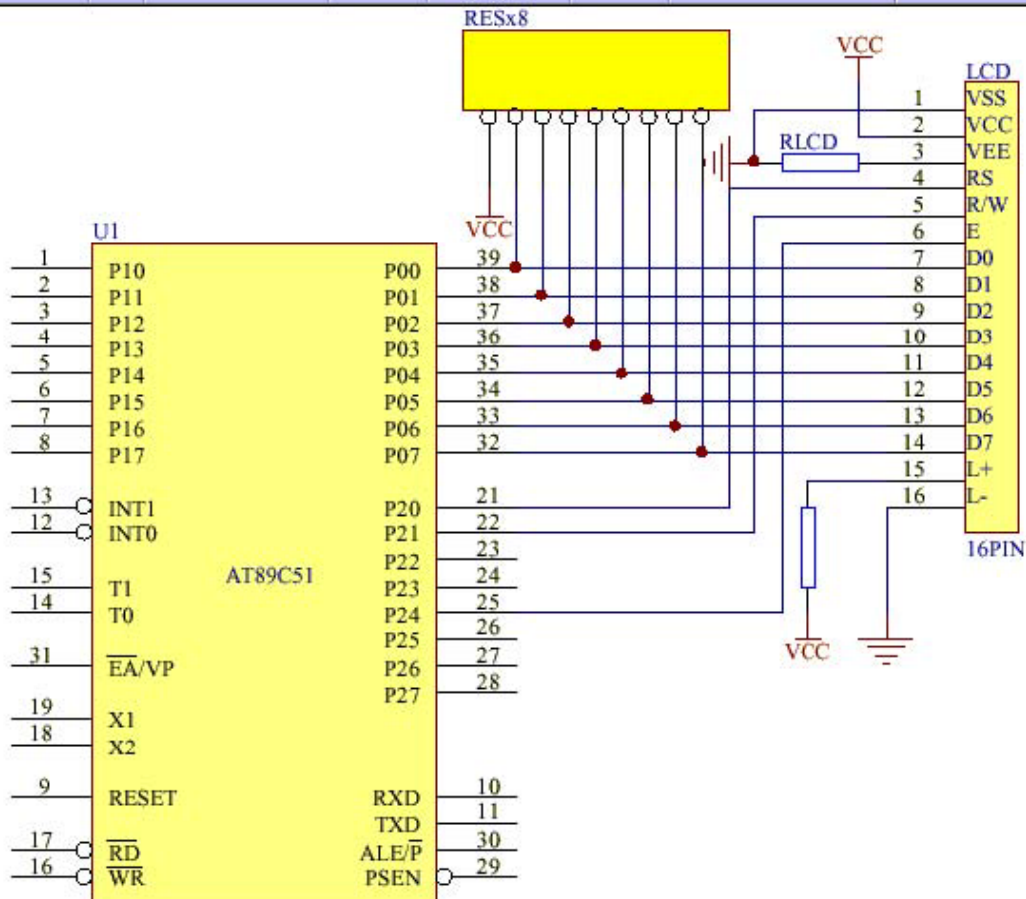

■ CGROM

Table 5. Relationship between Character Code (DDRAM) and Character Pattern (CGRAM)

Character Code (DDRAM data)								CGRAM Address						CGRAM Data								Pattern number
D7	D6	D5	D4	D3	D2	D1	D0	A5	A4	A3	A2	A1	A0	P7	P6	P5	P4	P3	P2	P1	P0	
0	0	0	0	x	0	0	0	0	0	0	0	0	0	x	x	x	0	1	1	1	0	pattern 1
											0	0	1				1	0	0	0	1	
											0	1	0				1	0	0	0	1	
											0	1	1				1	1	1	1	1	
											1	0	0				1	0	0	0	1	
											1	0	1				1	0	0	0	1	
											1	1	0				1	0	0	0	1	
											1	1	1				0	0	0	0	0	
0	0	0	0	x	1	1	1	0	0	0	0	0	0	x	x	x	1	0	0	0	1	pattern 8
											0	0	1				1	0	0	0	1	
											0	1	0				1	0	0	0	1	
											0	1	1				1	1	1	1	1	
											1	0	0				1	0	0	0	1	
											1	0	1				1	0	0	0	1	
											1	1	0				1	0	0	0	1	
											1	1	1				0	0	0	0	0	

Operation Example

```

#include <reg51.h>
#include <intrins.h>

sbit dc=0xa0;          /*P2.0   LCD's      21*/
                      RS
sbit rw=0xa1;          /*P2.1   LCD's   R/W 22*/
sbit cs=0xa4;          /*P2.4   LCD's      25*/
                      E
sfr  lcdbus=0x80;     /*p0LCD data D0=P0.0*/
unsigned int sys10mscounter;
unsigned char syslimitcounter;
char path1[8]={0x00,0x1f,0x00,0x1f,0x00,0x1f,0x00,0x1f};/*自定义符号      横1*/
char path2[8]={0x1f,0x00,0x1f,0x00,0x1f,0x00,0x1f,0x00};/*自定义符号      横2*/
char pats1[8]={0x15,0x15,0x15,0x15,0x15,0x15,0x15,0x15};/*自定义符号      竖1*/
char pats2[8]={0x0a,0x0a,0x0a,0x0a,0x0a,0x0a,0x0a,0x0a};/*自定义符号      竖2*/

void soft_nop(){}
void soft_10ms()/******12MHZ 提供10MS 软件延时*****/
{ register int i;
for(i=0;i<711;i++);

```

```

}
void soft_20ms()/******12MHZ 提供20MS 软件延时*****/
{
    soft_10ms();
    soft_10ms();
}
void hard_10ms(unsigned int delaytime) /*基于10MS 的硬件延时*/
{
    sys10mscounter=delaytime;
    while(sys10mscounter);
}
unsigned char data lcdcounter;
bit lcdusing1,lcdusing2;
bit lcd_checkbusy()/*检查LCD 忙*/
{
    register lcdstate;
    dc=0;          /*dc=1为数据,=0 为命令*/
    rw=1;         /*rw=1为读,=0 为写*/
    cs=1;         /*cs=1选通*/
    soft_nop();
    lcdstate=lcdbus;
    cs=0;
    return((bit)(lcdstate&0x80));
}
void lcd_wrcmd(unsigned char lcdcmd) /*写LCD 命令*/
{
    lcdusing1=1;
    while(lcd_checkbusy());
    lcdbus=lcdcmd;
    dc=0;          /*dc=1为数据,=0 为命令*/
    rw=0;         /*rw=1为读,=0 为写*/
    cs=1;         /*cs=1选通*/
    soft_nop();

    cs=0;
    lcdbus=0xff;
    lcdusing1=0;
}

void lcd_moveto(char position) /*移动光标到指定位.0-79*/
{ register cmd=0x80;

    lcdcounter=position;
    if (position > 59)
        position += 0x18;
    else

```

```

    { if (position > 39)position -= 0x14;
      else
        { if (position > 19)position += 0x2c;
          }
    }

cmd=cmd|position;
lcd_wrcmd(cmd); } void lcd_wldata(char lcddata) /*在当前显示位置显示数据*/ { char i;
lcdusing2=1;
while(lcd_checkbusy());
if(lcdcounter==20){

    lcd_moveto(20);
    while(lcd_checkbusy());
}

if(lcdcounter==40){
    lcd_moveto(40);
    while(lcd_checkbusy());
}

if(lcdcounter==60){
    lcd_moveto(60);
    while(lcd_checkbusy());
}

if(lcdcounter==80){
    lcd_moveto(0);
    while(lcd_checkbusy());
    lcdcounter=0;
} /*为通用而如此*/

lcdcounter++;
lcdbus=lcddata;
dc=1; /*dc=1为数据,=0 为命令*/
rw=0; /*rw=1为读,=0 为写*/
cs=1; /*cs=1选通*/
soft_nop();
cs=0;

lcdbus=0xff;
lcdusing2=0;} void lcd_string(char *strpoint) /*在当前显示位置显示LCD 字符串*/
{ register i=0;
  while(strpoint[i]!=0){

```



```

        lcd_wrddata(strpoint[i]);
        i++;
    }

} void lcd_init()/*初始化*/

{
    lcd_wrcmd(0x38);    /*设置8 位格式,2 行,5*7*/
    lcd_wrcmd(0x0c);    /*整体显示,关光标,不闪烁*/
    lcd_wrcmd(0x06);    /*设定输入方式,增量不移位*/
    lcd_wrcmd(0x01);    /*清除显示*/
    lcdcounter=0;
}

void lcd_cls()/*清除显示*/ { lcd_wrcmd(0x01);
    lcdcounter=0;} void timer0(void) interrupt 1 /*T0 中断*/ { TH0=0xd8; /*12M,10ms*/
    TL0=0xf6;
    TR0=1;
    if(sys10mscounter!=0)sys10mscounter - -; /*定时器10ms*/
    if(syslimitcounter!=0)syslimitcounter - -; /*定时器10ms*/

}

    main()
    {
        unsigned char j;
        IE=0;P0=0xff;P1=0xff;P2=0xff;P3=0xff; /*初始化T*/
        lcd_init();soft_20ms();
        TMOD=0x51;
        TH0=0xd8; /*12M,10ms*/
        TL0=0xf6;
        TR0=1;ET0=1;EA=1;

        while(1)
        {
            /*全黑横一横二竖一竖二U Q ABCD... */
            lcd_init(); /*全黑*/
            for(j=0;j<80;j++){lcd_wrddata(0xff);}
            hard_10ms(50);
            lcd_init(); /*横一可参考自行设计符号*/
            lcd_wrcmd(0x40);
            for(j=0;j<8;j++){lcd_wrddata(path1[j]);

            for(j=0;j<100;j++){lcd_wrddata(0);
            hard_10ms(50);
            lcd_init(); /*横二*/

```

